

SPECIFICATIONS

Observation method	Transmitted light: brightfield, Nomarski DIC, simple polarizing, and oblique illumination observation Reflected light: Fluorescence, Nomarski DIC, coaxial illumination, and LED illumination observation
Total magnification	5x to 400x (depends on the combination of eyepiece lenses and objective lens), 6.25x to 500x when a coaxial illuminator is mounted
Zoom range	1 to 8 (zoom ratio: 8:1)
Eyepiece tubes	0.6x reduction optics built into photo port AZ-TE100 Ergonomic Trinocular Tube 100 (bino: photo 100:0/0:100), AZ-TE80 Ergonomic Trinocular Tube 80 (bino: photo 100:0/20:80), and AZ-TP DSC Tube 0.6x (direct tube type)
Inclination angle	0° to 30° (with AZ-TE100/AZ-TE80 eyepiece tube)
Interpupillary adjustment range	50 to 75mm (with AZ-TE100/AZ-TE80 eyepiece tube)
Eyepiece lens	AZ-W 10x (FOV: 22mm)
Focus mount adapters	AZ-FM Focusing Mount Adapter (for AZ-STE/STD stand), AZ-SMZ SMZ Focusing Mount Adapter (for SMZ plain stand/BD stand), and AZ-LV LV Focusing Mount Adapter (for LV-IMA/LV-IM)
Stands	AZ-STD Diascopic Stand/AZ-STE Episcope Stand: (focus mount section: focusing stroke, 85mm; coarse, 18.5mm/rotation; fine, 3.27mm/rotation) Stage focus section: focusing stroke, 10mm; coarse, 37.7mm/rotation; fine, 0.27mm/rotation) C-PS160 Plain Stand, C-BD Diascopic Bright/Darkfield Stand
Stages	AZ-STGD DIA Stage (150 x 100mm stroke), AZ-STGE EPI Stage (150 x 150mm stroke)
Objective lens mounts	AZ-NP3 Triple Nosepiece, AZ-NPS Single Nosepiece, AZ-FLDIC FL-DIC Prism Holder (used when simultaneously mounting epi-fluorescence and diascope DIC attachments)
Objective lenses	AZ-Plan Apo 0.5x (NA: 0.05/WD: 54mm), AZ-Plan Apo 1x (NA: 0.1/WD: 35mm), AZ-Plan Fluor 2x (NA: 0.2/WD: 45mm) AZ-Plan Apo 4x (NA: 0.4/WD: 20mm), AZ-Plan Fluor 5x (NA: 0.5/WD: 15mm)
Illuminators	Diascopic illuminator: AZ-STD Diascopic Stand (100W halogen), Episcope illuminator: AZ-ICI Coaxial illuminator (device magnification:1.25x, 100W halogen), C-FID Plastic Fiber Optics Bifurcated Illuminator (100W halogen), AZ-LED LED Ring Illuminator (LED), Epi-fluorescence illuminator: C-HGFI/HGFIE HG Precentered Fiber Illuminator (manual/motorized, 130W mercury), Lamphouse HMX-4B (100W mercury)
Epi-fluorescence attachment	AZ-FL Epi-fluorescence Attachment (up to four filter cubes mountable)
Power consumption	C-FI115/230 Fiber Illuminator: 2.3A, HG Precentered Fiber Illuminator: 2A
Weight	Epi-fluorescence + diascope DIC configuration: 28kg

DIMENSIONS

Epi-fluorescence + diascope DIC configuration

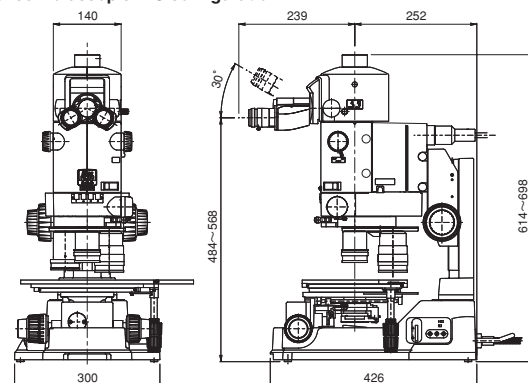

Diascopic DIC configuration

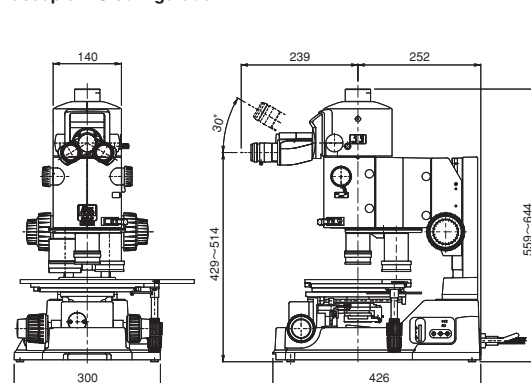

Examples on cover: (First and second images from the left) Primary culture cells from the cerebellum of an 18-day-old mouse embryo. Fixed and double immunofluorescence stained on seventh day of cultivation. (Third image) Rat skull base (Fourth image) Rat spinal cord/HRP labeling, counterstaining with cresylviolet (Fifth image) Zebra fish

Samples provided by: Center of cover, second from right, and pages 2 and 3: Professor Tetsuo Sugimoto (Faculty of Medicine, Kansai Medical University Department of Anatomy and Brain Science)
First and second from left side of cover and epifluorescence on page 4: Teichi Furuichi, Ph.D. Lab. Head and Noriyuki Morita, Ph.D. (Brain Science Institute, RIKEN)
First from right side of cover and differential interference on the bottom of page 4: Hitoshi Okamoto MD, Ph.D. Lab. Head and Hideomi Tanaka, Ph.D. (Brain Science Institute, RIKEN)

Specifications and equipment are subject to change without any notice or obligation on the part of the manufacturer. August 2009 ©2007/2008/2009 NIKON CORPORATION

The products detailed in the brochure are controlled by the Japanese Foreign Exchange and Foreign Trade Law and the International Export Control Regime. If there is a possibility that they may be utilized for the development of weapons of mass destruction, etc., they shall not be exported without authorization from the government.

WARNING TO ENSURE CORRECT USAGE, READ THE CORRESPONDING MANUALS CAREFULLY BEFORE USING THE EQUIPMENT.



NIKON CORPORATION

6-3, Nishiohi 1-chome, Shinagawa-ku,
Tokyo 140-8601, Japan
phone: +81-3-3773-8973 fax: +81-3-3773-8986
<http://www.nikon.com/instruments/>



NIKON INSTRUMENTS INC.

1300 Walt Whitman Road, Melville, N.Y. 11747-3064, U.S.A.
phone: +1-631-547-8500; +1-800-52-NIKON (within the U.S.A. only)
fax: +1-631-547-0306

<http://www.nikoninstruments.com/>

NIKON INSTRUMENTS EUROPE B.V.

Laan van Kronenburg 2, 1183 AS, Amstelveen, The Netherlands
phone: +31-20-44-96-300 fax: +31-20-44-96-298

<http://www.nikoninstruments.eu/>

NIKON INSTRUMENTS (SHANGHAI) CO., LTD.

CHINA phone: +86-21-5836-0050 fax: +86-21-5836-0030
(Beijing branch) phone: +86-10-5869-2255 fax: +86-10-5869-2277
(Guangzhou branch) phone: +86-20-3882-0552 fax: +86-20-3882-0580

NIKON SINGAPORE PTE LTD.

SINGAPORE phone: +65-6559-3618 fax: +65-6559-3668

NIKON MALAYSIA SDN. BHD.

MALAYSIA phone: +60-3-7809-3688 fax: +60-3-7809-3633

NIKON INSTRUMENTS KOREA CO., LTD.

KOREA phone: +82-2-2186-8410 fax: +82-2-555-4415

NIKON CANADA INC.

CANADA phone: +1-905-602-9676 fax: +1-905-602-9953

NIKON FRANCE S.A.S.

FRANCE phone: +33-1-4516-45-16 fax: +33-1-4516-45-55

NIKON GMBH

GERMANY phone: +49-211-941-42-20 fax: +49-211-941-43-22

NIKON INSTRUMENTS S.p.A.

ITALY phone: +39-055-300-96-01 fax: +39-055-30-09-93

NIKON AG

SWITZERLAND phone: +41-43-277-28-67 fax: +41-43-277-28-61



MULTI-PURPOSE ZOOM MICROSCOPE

MULTIZOOM
AZ100

Broad application range, from high to lower power, in a single microscope

The AZ100 represents an all-new concept in zoom microscopes. It covers a wide range of magnifications, from 5x to 400x, all in a single microscope. Thanks to a smooth zooming mechanism combined with the triple nosepiece, the AZ100 can continuously switch magnifications extending from macro to micro observation of the same specimen. Enjoy the combined advantages of a stereoscopic microscope with a wide field of view and a long working distance, and a biological microscope boasting high-resolution images — AZ100 is Nikon's latest groundbreaking microscope solution.



Offers a long working distance. Even allows the observation of Petri dishes from above.



Epi-fluorescence + diascopic Nomarski DIC configuration



Mouse cerebrum slice/ Enkephalin immunostaining
*Using Plan Apo 1x objective lens

Rat cerebrum slice/ Toluidine blue staining
*Using Plan Apo 1x objective lens

On-axis images capturing capability

Since stereoscopic microscopes produce three-dimensional images using binocular viewing, the image from each eyepiece tube has some degree of inclination. Consequently, images captured by cameras will also have such inclination. To counteract this, the AZ100 employs a vertical optical system, which allows the user to capture images from directly above while zooming, without any inclination whatsoever.

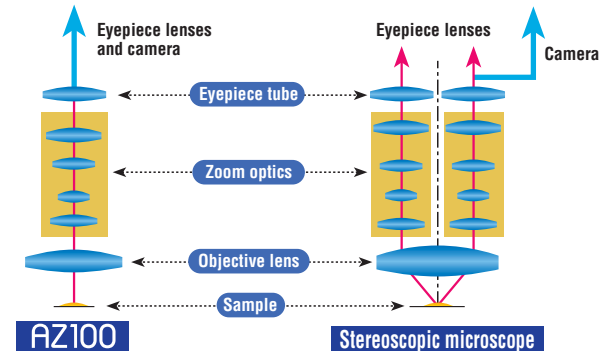
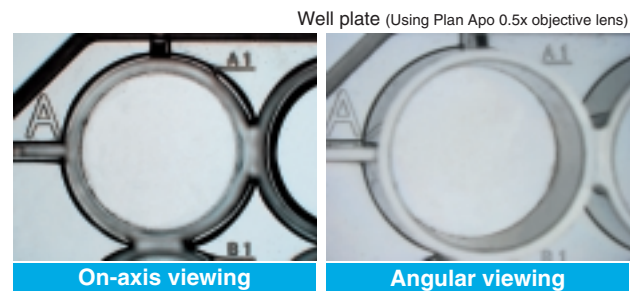

FUNCTIONAL DESIGN

A wide range of magnifications

By combining 8x zoom optics (1 to 8x magnification) with a three-position objective nosepiece, the AZ100 enables observation at a magnification ratio of 80:1, the highest level of any such device in the world. The objective lens lineup consists of 0.5x, 1x, 2x, 4x, and 5x lenses.

When combined with 10x eyepiece lenses, the AZ100 covers a wide range of magnifications, from 5x to 400x. And since the zooming knob features click-stops, it is easy to set magnification without removing your eyes from the eyepiece tube.



Zooming knob with click-stops



Three objective lenses can be simultaneously mounted to provide large zooming ratio.

Comes standard with an aperture stop

The AZ100 ships complete with an aperture stop that is effective not only for visual observation, but also for the capture of digital images. This aperture stop allows you to freely change contrast and the depth of field based on your specimen requirements.



Aperture stop dial

Comparative examples

Sample: Rat jaw (*Using Plan Apo 0.5x objective lens)

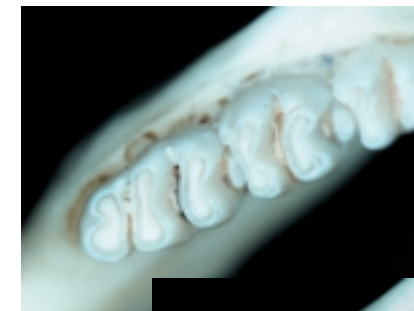

Aperture stop open



Aperture stop closed

Ergonomic tilting eyepiece tubes

The AZ100 comes standard with tilting trinocular eyepiece tubes that tilt from 0° to 30° to allow the optimal eye level for the observer's height and posture. Two different beamsplit ratios for the binocular and photo port can be selected: the 100:0/0:100 type, which is optimal for photo documentation, or the 100:0/20:80 type, which enables visual observation while displaying an image on a monitor.



Double-coarse/fine focusing system

Focusing can be done using the focus knob either on focus mount or stage with the dedicated stand (AZ-STD/STE). The 85mm stroke on the focus mount and the 10mm stroke on the stage enable the observation of tall samples. The focus knob on the stage allows the user to focus the microscope in a comfortable position, without having to reach over the sample.

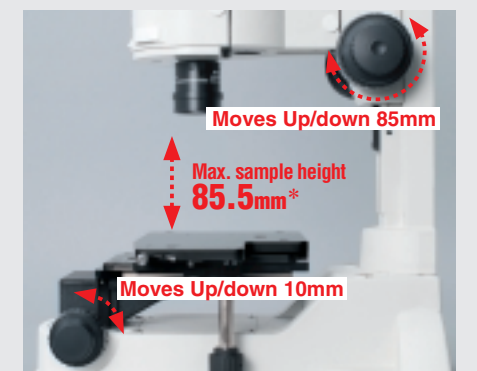

*Differs depending on the objective lens and stand combination.

HIGH VERSATILITY

In addition to brightfield observation, a wide range of observation methods are possible, including epi-fluorescence, Nomarski DIC, simple polarizing, and oblique illumination.

AZ100 enables Simultaneously mounting of epi-fluorescence and diascope DIC attachments which allows for switching between each observation mode easily.

Epi-fluorescence observation

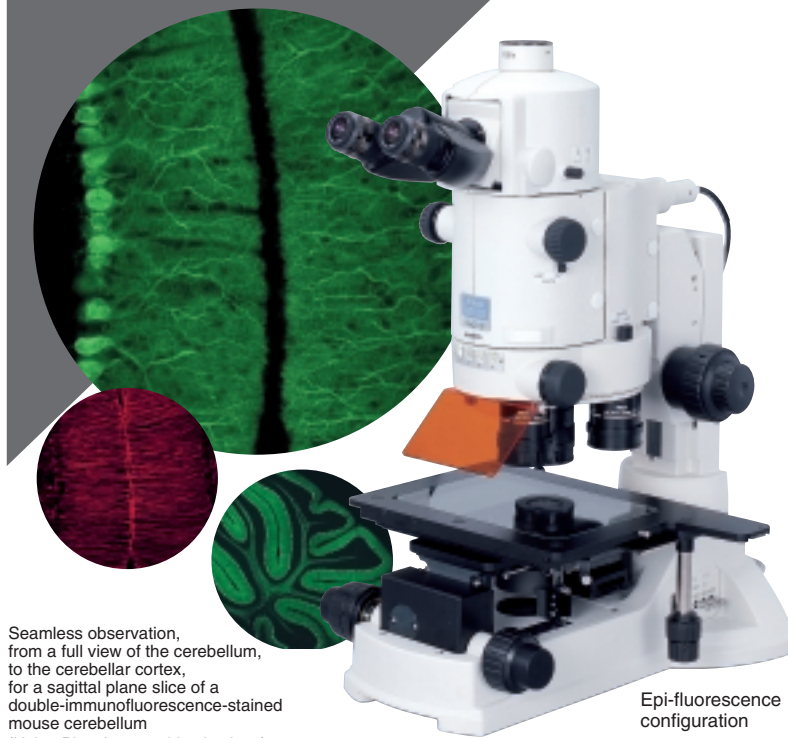

Seamless observation, from a full view of the cerebellum, to the cerebellar cortex, for a sagittal plane slice of a double-immunofluorescence-stained mouse cerebellum (Using Plan Apo 4x objective lens)

Epi-fluorescence configuration

Epi-fluorescence Accessories

Since the excitation light path of AZ100 is separated from the observation optics, fluorescence images with high S/N ratio can be obtained, without being affected by zooming lenses. The newly developed HG precentered fiber illuminator minimizes thermal effects on the microscope itself, and there is no need for troublesome lamp-centering adjustment.

Note: For UV excitation, the lamp-housing type mercury lamp (S) is recommended.



- 1 C-HGF/HGFIE HG Precentered Fiber Illuminator (130W), HG Fiber
- 2 AZ-FL Epi-Fluorescence Attachment
- 3 AZ-HGFA Fiber Adapter
- 4 Fluorescence Filter Cubes
- 5 C-SHG1 Starter 100W, Lamphouse HMX-4B, AZ-HGA HG Lamphouse Adapter

Nomarski DIC observation



Zebra fish embryo (Using Plan Fluor 5x objective lens)

Diascopic DIC configuration

Nomarski DIC Accessories

Thanks to the newly developed DIC prisms, high-contrast DIC images with uniform coloration are possible at any magnification. (The objective lenses capable of DIC observation are the Plan Apo 1x, Plan Apo 4x, and Plan Fluor 5x.)

Note: The AZ-FLDIC FL-DIC Prism Holder is required to simultaneously mount this accessory along with the AZ-FL Epi-Fluorescence Attachment.



- 1 AZ-DPS1 DIA Prism Slider 1-4x
- 2 AZ-DPS5 DIA DIC Prism Slider 5x
- 3 AZ-AN DIA DIC Prism Holder with Analyzer
- 4 AZ-DP1 DIA DIC Prism 1x
- 5 AZ-DP4 DIA DIC Prism 4x
- 6 AZ-DP5 DIA DIC Prism 5x
- 7 AZ-RP Rotatable Polarizer
- 8 AZ-DL DIA DIC Lambda Plate

ACCESSORIES

Nikon has a variety of accessories supporting low to high-power zooming, a wide array of specimen, including large samples, Petri dishes, and glass slides, and even transparent colorless samples.

Objective Lenses

Nikon has developed new dedicated objective lenses with a high NA and low distortion. There are five lens types, each of which suit different illumination techniques.

List of objectives specs

	Plan Apo 0.5x	Plan Apo 1x	Plan Fluor 2x	Plan Apo 4x	Plan Fluor 5x (include correction ring)
	Parfocal				
WD	54mm	35mm	45mm	20mm	15mm
NA	0.05	0.1	0.2	0.4	0.5
DIC	—	○ EPI/DIA	—	○ EPI/DIA	○ EPI/DIA
Epi-fluorescence	○	○	○ (UV excitation possible)	○	○ (UV excitation possible)
LED illumination	○	○	—	—	—
Coaxial illumination	○ (with lambda plate)	○ (with lambda plate)	—	○ (with lambda plate)	○ (with lambda plate)



- 1 AZ-Plan Apo 0.5x
- 2 AZ-Plan Apo 1x
- 3 AZ-Plan Fluor 2x
- 4 AZ-Plan Apo 4x
- 5 AZ-Plan Fluor 5x

Oblique Illumination Slider

By inserting the sliding diaphragm at a conjugated position with the objective pupil, the center of the light beam is shielded allowing coherent light to be projected obliquely onto the sample. This allows observation of transparent colorless samples by applying relief-like contrast with a shadow.

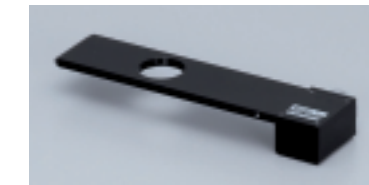

AZ-OI Oblique Illumination Slider

LED Ring Illuminator

This high-intensity reflected illuminator features a long-life white LED. It includes a intensity control function that provides stable and even illumination.



AZ-LED LED Ring Illuminator

Diascopic Illumination Stand/Stage

By combining a variety of holders with a diascope illumination stand and a stage, various observation methods are possible including brightfield, Nomarski DIC, simple polarizing for everything from large samples to Petri dishes and glass slides.



AZ-STD Diascopic Stand, AZ-STGD DIA Stage, AZ-SG Stage Glass



- 1 AZ-SDA Dish Holder Adapter
- 2 AZ-SRP Rotatable Plate

Used together with the AZ-SDA dish holder adapter or AZ-SRP rotating plate



- 1 φ35mm Petri dish holder
- 2 Hemacytometer holder
- 3 C-HU Universal holder
- 4 C-HSG Slide glass holder
- 5 C-HT Terasaki holder

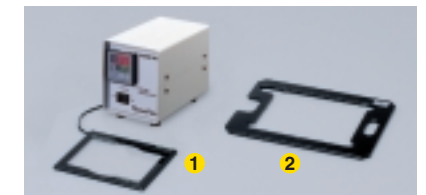

- 1 Thermo Plate® MATS-U505S (TOKAI HIT Co., Ltd.)
- 2 AZ-STA Thermo Plate Adapter



- 1 Stage Top Incubator (TOKAI HIT Co., Ltd.)
- 2 Stage Adapter AZS-ZA

*This product is not compatible with AZ-Plan Fluor 5x.

DIGITAL CAMERA

DIGITAL SIGHT SERIES

A flexible system that enables various configurations consisting of a camera head and a control unit to suit the needs of any sample or application.

Camera Head



High-definition color camera head **DS-Fi1**

5-megapixel high-definition color. The DS-Fi1 offers advanced performance, including a wide dynamic range and superior red sensitivity, and is optimal for brightfield, darkfield, phase contrast, and DIC image capture.



Cooled camera head for high-definition color images **DS-Fi1c**

5-megapixel high-definition color. The DS-Fi1c uses the Peltier cooling mechanism to cool the CCD to 20°C below the ambient temperature. When capturing fluorescence images where long exposures are required, thermal background noise is suppressed, enabling you to obtain high-contrast images.

Stand-alone Control Unit

DS-L2

The DS-L2 features a large high-definition LCD, which allows users to capture images without connecting to a PC. It is packed with user-friendly features, such as "scene mode", which automatically adjusts optimal camera settings after the user selects an observation method. Nikon also offers the DS-U2 control unit for processing and analyzing images on a PC.



Large, high-definition monitor

The unit has a built-in 8.4-inch TFT LCD monitor with 1,024 x 786 pixels, and 400:1 contrast.

Easy-to-use toolbar

Frequently used features are displayed as toolbar buttons. It is also possible to customize the buttons.



Example of toolbar buttons (Left: Short/Right: Large)

Scene mode: optimal image capture with a single button

Users can set the optimal capture conditions simply by clicking the observation method they want to select. They can also register custom modes.

Scene mode menu



An extensive array of tool functions

Users can measure captured images and enter such things as lines and comments.

- Count markers
- Superimposition (semitransparent image overlay for comparative purposes)
- Scale display/alignment: scale, XY scale, screen pattern, grid lines, and XY measurement



See the Digital Sight series catalog for more information.

SYSTEM DIAGRAM

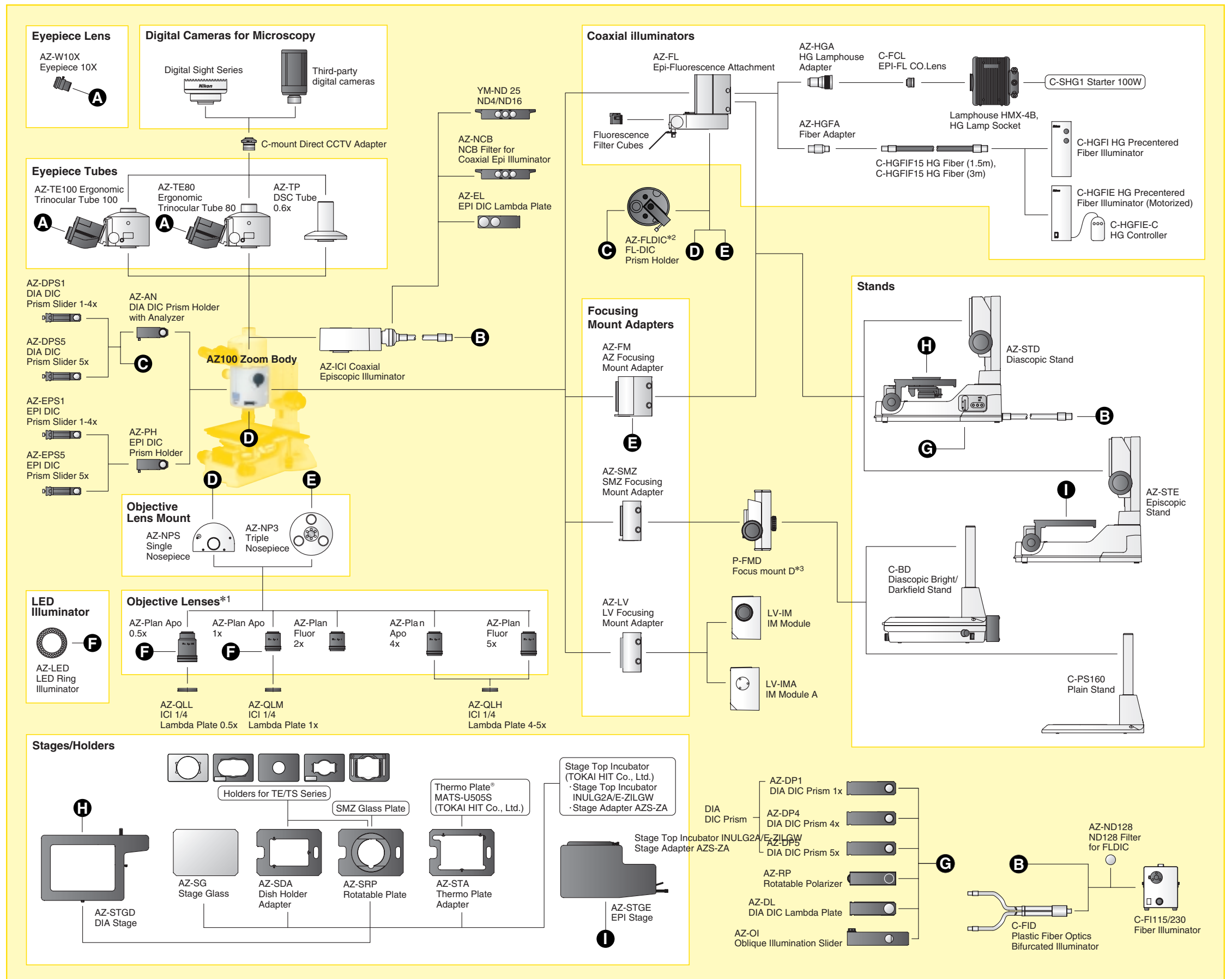

*1 See page 5 regarding combinations with illuminators. *2 Use when simultaneously mounting epi-fluorescence and diascopic DIC attachments. *3 Combination with coaxial illuminator is not possible.